



- + Capacity: 29 bottles*:
- upper part: 12 bottles
- lower part: 17 bottles
- + Vinotag compatible** 
- + Built-under counter installation
- + Design: black
- + Cooling system: compressor
- + Type of cold: air moving system
- + Adjustable temperature ranges of use:
- upper part: 5°C-12°C
- lower part: 12°C-20°C
- + Electronic regulation
- + Thermometer with white digital display
- + White LED lights with switch button
- + Humidity control: natural (hygrodynamic concept)
- + 1 reversible glass door, anti-UV treated, 3-layers tempered E-Low glass (grey-colored)

FULL OPTION RANGE

The PLATINUM range is equipped with wooden shelves on **telescopic rails with labels prominent**.

Adapt the colour of the lighting and its intensity according to the atmosphere of the kitchen. Choose between **3 colours** (Cool White, Warm White, Amber) and **4 intensity levels** (25%, 50%, 75%, 100%).

THE BEST OF INSTALLATION

The PLATINUM range **brings together the best** for easy installation in any kitchen.

A **self-ventilating system** ensuring heat evacuation without the need for high and low ventilation.

An **electronic PUSH-PULL opening with pantograph hinges** for smooth opening and closing.

Reversibility possible for door opening.

The AVI72PLATINUM is specially designed to be installed under a worktop and be perfectly aligned with a door height of 72 cm.

CONNECTED 24 H

Equipped with a remote-control function, you can control the temperature, lighting, and alarms, from the **Vinotag®** app, at any time, from your smartphone.

Thanks to temperature alerts, **you can be alerted at any time** to make a quick decision to protect your precious bottles.



Eco-responsibility

Our products are manufactured in compliance with European environmental rules. Especially, refrigerant fluid (R600a) doesn't reject neither CFC nor HFC and respect environment.

Energy consumption is calculated based on the result obtained for 24h in standard test conditions. The actual energy consumption depends on the conditions of use and location of the device.

This equipment is designed to be used in an ambient temperature between 16-38°C.

This appliance is intended to be used exclusively for the storage of wine.

Alcohol abuse is dangerous for health, please consume in moderation.

*Capacity given as an indication with 75cl Bordeaux traditional type bottles and measured with 5 shelves. Adding shelves reduce considerably the total capacity.

**Thanks to the Vinotag® application, benefit from a digital register of your wine cellar and be alerted of the peak dates of your wines. In partnership with Vivino, scan your bottle to access its pre-filled wine sheet.

Built-under counter with a niche

AVI72PLATINUM 2-compartments service wine cabinet Built-in column range

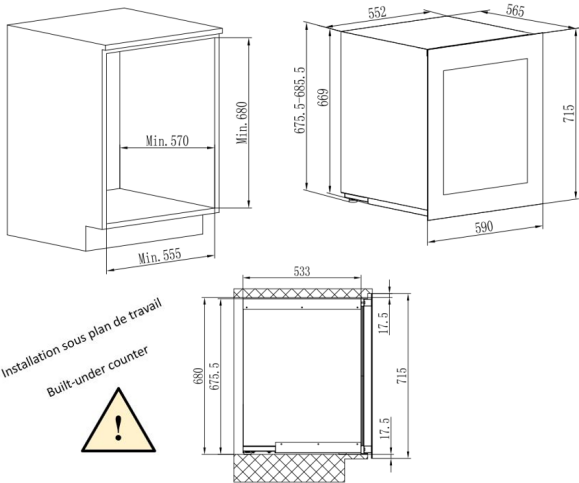

> EQUIPMENTS INCLUDED

- 3 sliding wooden shelves (solid sapele)
- 1 sliding wooden half-shelf (solid sapele)
- 4 adjustable feet (height 6.5 cm)
- 1 active charcoal filter
- Anti-vibration system

> TECHNICAL CHARACTERISTICS

- Energy class: F
- Annual electrical consumption: 101 kWh
- Climatic class: ST
- Noise level: 37 dB
- EEI: 123.00
- Voltage: 220 V
- Power input: 145 W
- Category: 2 - Wine cellar
- Type of gas: R600a

> SAFETY

- **Child lock:** locks the control panel
- **Visual and audible alarms:** notify you when your attention is required

> VINOTAG® APPLICATION

Free wine cellar management application. Access a virtual representation of your wine cellar and a detailed inventory of its contents.

> COMPATIBLE ACCESSORIES

Only available in spare parts

> LOGISTIC DATAS

Gross dimensions (WxDxH cm)	: 65 x 66,5 x 76
Net dimensions (WxDxH cm)	: 59 x 56,5 x 71,5
Gross weight (kg)	: 54.00
Net weight (kg)	: 49.00
Full truck (pcs)	: 0
Container (pcs)	20' : 72
	40' : 162
	40' HC : 216

Gencod 3595320107913