

## OZ90DX-24



Ageing and Service Wine Cellar  
Oslo series  
Built-in column

### GENERAL INFORMATION

**Number of bottles : 41**  
**Number of zones : 2**  
**Adjustable temperature range : 5-20°C**  
**Noise level : 38dB**  
**Energy class : G**  
**Climate class : N/ST (16-38)**  
**Vinotag compatible : Yes**



### Product description

#### Modern wine cabinet with high-end technology

High quality wine cabinet with Scandinavian design and optimal storing conditions. The stylish design with stainless steel front, beech wooden shelves and interior LED-lighting will add a stylish touch to your kitchen space. Equipped with a digital display and touch panel that allows you to easily adjust temperature and lighting.

This model is designed for installation in kitchen columns, and requires measures for proper ventilation.

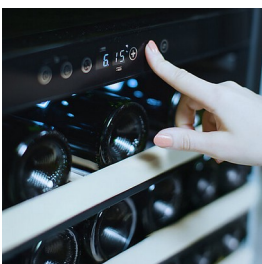

#### Touch panel & digital display

Easy and intuitive control of temperature and lighting.

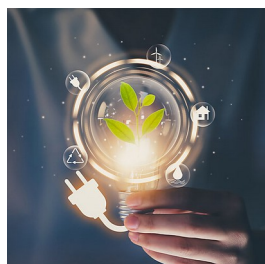

#### Improved efficiency

New and improved energy efficiency with lower sound levels.

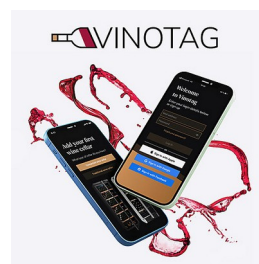

#### Vinotag compatible

View and manage your wine collection on the go with the Vinotag-application.

# OZ90DX-24

EAN-13 - 7073437000410

## Capacity and Temperature

- **Number of bottles: 41**
  - Upper zone : 12
  - Lower zone : 29
- **Adjustable temperature: 5-20°C**
  - Upper zone : 5-12°C
  - Lower zone : 12-20°C

## Door

**Number of glass layers :** 2  
**Anti-UV :** Yes  
**Lock :** No  
**Reversible door :** Yes  
**Handle type :** Pulling bar  
**Door dimensions (WxDxH) :** 59x4x88.5

## Security

**Alarm :** Door

## Logistic

**Net dimensions (WxDxH):** 59.0 x 57.0 x 88.9  
**Gross dimensions (WxDxH):** 655.0 x 680.0 x 97.0  
**Net weight (kg) :** 49.7  
**Gross weight (kg) :** 54.5

## Technical Data

**Energy class :** G  
**Annual energy (KWh/a) :** 142  
**Climate class :** N/ST (16-38)  
**Noise level :** 38dB /  
**Power input :** 75.00 W  
**Voltage :** 220-240 V  
**Length of power cable :** 150 cm  
**Plug Type :** F type  
**Type of gas :** R600a  
**Gas charge :** 30 g  
**Type of compressor :** Embraco  
**Main cooling system :** Air moving system  
**Charcoal filter :** 2  
**Anti-vibration system :** No  
**Adjustable feet :** 4 / cm

## Light

**Light source :** LED  
**Light color(s) :** White  
**Dimmable light :** no  
**Light switch :** no

**Qty per 20' :** 48  
**Qty per 40' :** 108  
**Qty per 40 HC:** 144  
**Customs code:**

# OZ90DX-24

EAN-13 - 7073437000410

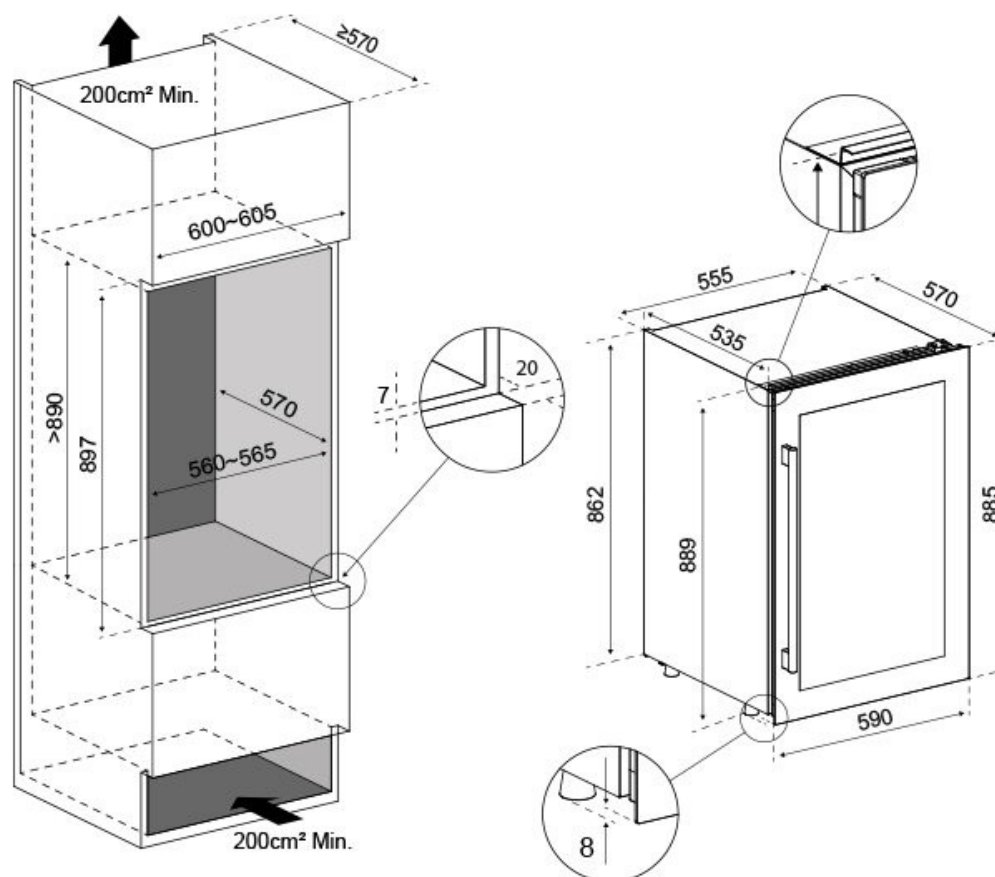

## Accessories

- 6 shelves, wooden with natural wood front, sliding
- 2 charcoal filters, (FILTRE7)

## Built-in information

**Built-in dimensions (WxDxH) :** 555.00 x 535.00 x 889.00

**Self ventilation system :** No